

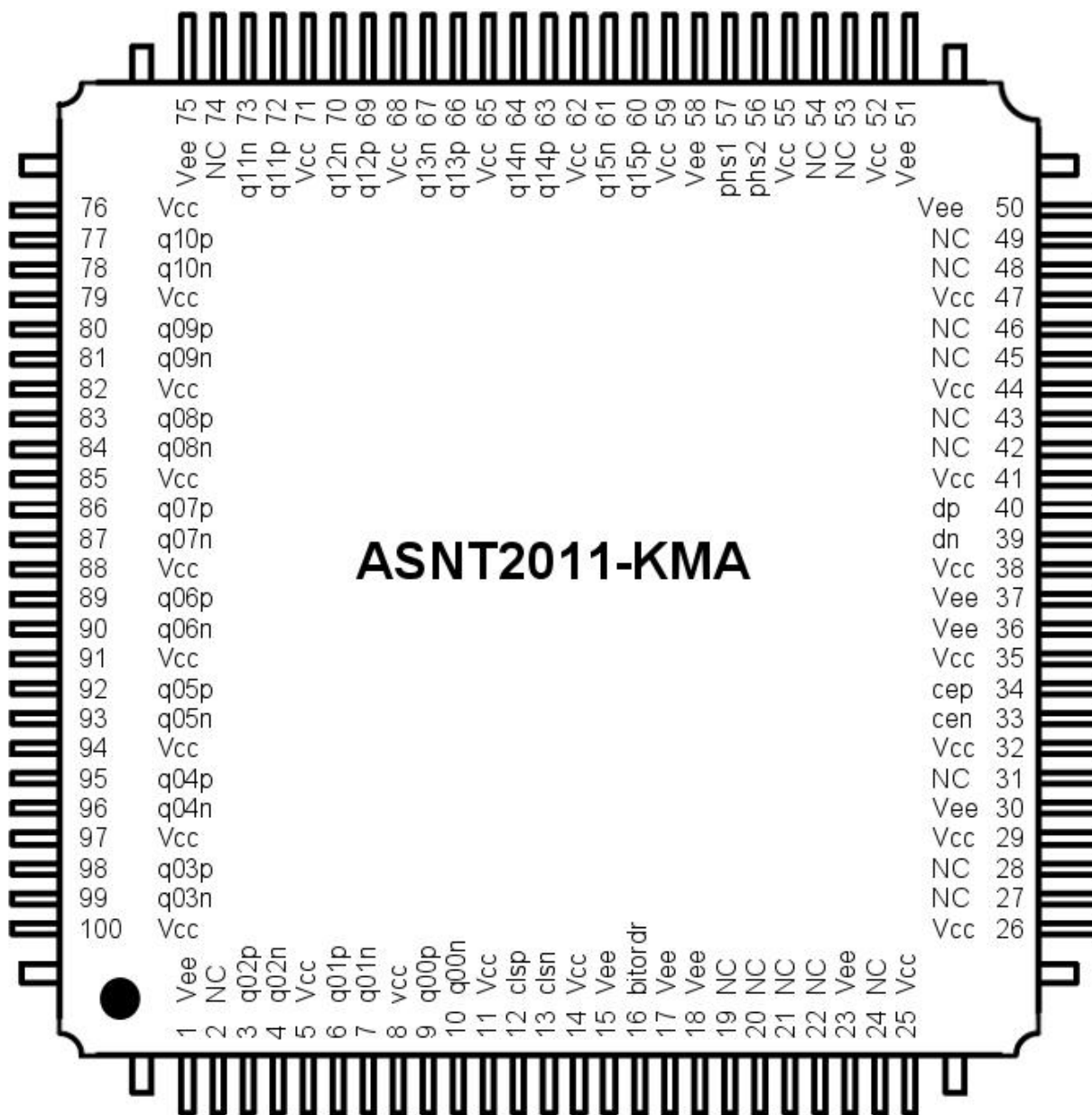

## ASNT2011-KMA DC-to-17Gbps Digital Demultiplexer 1:16 / Deserializer

- Broadband digital deserializer 1-to-16.
- Low-power LVDS output data buffers with a proprietary architecture.
- Clock-divided-by-16 LVDS output buffer with 90°-step phase selection.
- Single +3.3V power supply.
- Industrial temperature range.
- Low power consumption of 730mW at 17Gbps.
- Custom 100-pin CQFP package (13mm x 13mm).





## DESCRIPTION

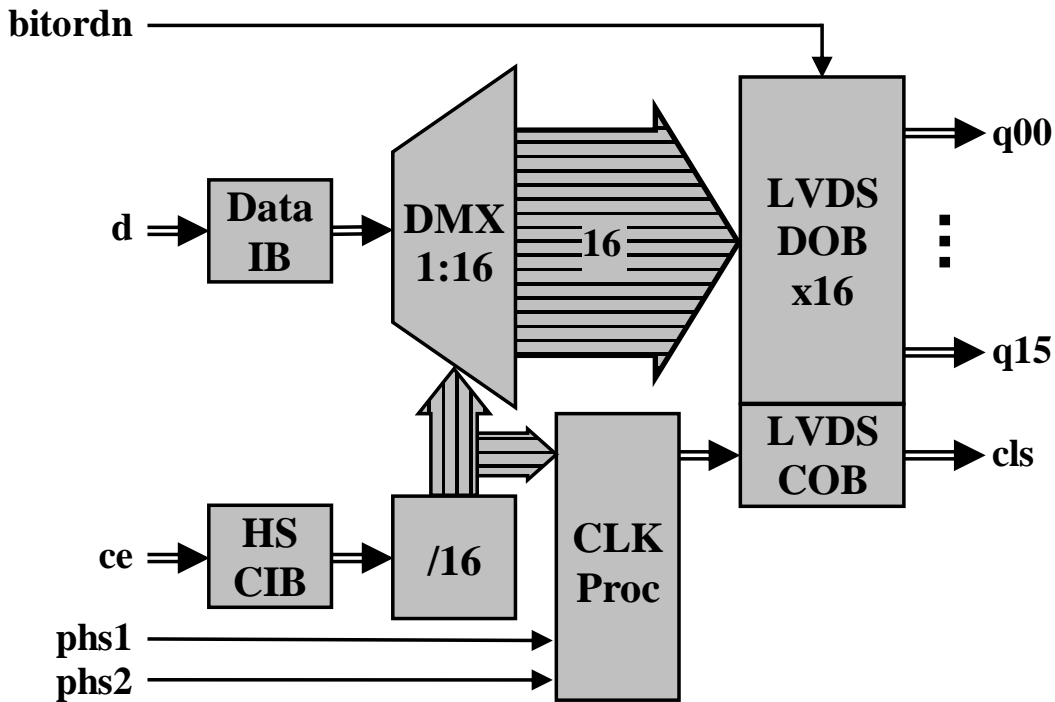

Fig. 1. Functional Block Diagram.

ASNT2011-KMA is a low power and high-speed digital 1 to 16 demultiplexer / deserializer IC. The IC shown in Fig. 1 can function seamlessly over input data rates ( $f_{bit}$ ) ranging from DC to 17Gbps.

The main function of ASNT2011-KMA is to demultiplex a serial input data channel “d” running at a bit rate of  $f_{bit}$  into 16 parallel data channels q00-q15 running at a bit rate of  $f_{bit}/16$ . The high sensitivity data input buffer (Data IB) ensures accurate operation at low input data signal amplitudes. It provides on-chip 50 $\Omega$  termination to VCC and is designed to be driven by devices with 50 $\Omega$  source impedance.

During normal operation, the received serial input data is latched into the tree-type demultiplexer DMX1:16 and subsequently deserialized and delivered to the demultiplexer’s output as 16-bit wide low-speed parallel words. The output MSB corresponds to q00 when bitordn=0 (default), or to q15 when bitordn=1.

A full rate clock must be provided by an external source ce to the high-speed clock input buffer HS CIB where it is routed to the internal divider-by-16 (/16). The divider provides signaling for DMX1:16 and produces a full rate clock divided-by-16 C16 for the low speed LVDS compliant clock output buffer LVDS COB. The phase of cls can be modified by 90° increments by utilizing pins phs1 and phs2 and the clock processing block CLK Proc.

Sixteen proprietary low-power LVDS output data buffers LVDS DOBx16 are used to deliver the 16 data output signals q00-q15 while a similar LVDS clock output buffer LVDS COB outputs the low-speed clock signal cls.

The deserializer uses a single +3.3V power supply and is characterized for operation from -25°C to 125°C of junction temperature.



## Data IB

The Data Input Buffer (Data IB) can process an input CML data signal **d** with bit rates from DC to  $f_{bit}$ . It can also accept a single-ended signal to one of its pins with a threshold voltage applied to the unused pin. Data IB can handle a wide range of input signal amplitudes. The buffer utilizes on-chip single-ended termination of  $50\Omega$  to **vcc** for each input line.

## HS CIB

The High-Speed Clock Input Buffer (HS CIB) can process an external CML clock signal **ce** with frequencies from DC to  $f_{bit}$ . It can also accept a single-ended signal to one of its pins with a threshold voltage applied to the unused pin. HS CIB can handle a wide range of input signal amplitudes. The buffer utilizes on-chip single-ended termination of  $50\Omega$  to **vcc** for each input line.

## /16

The Divider-by-16 (/16) includes 4 divide-by-2 circuits connected in series. The high-speed clock delivered by HS CIB is fed into the first divide-by-2 where its output is routed internally to the next divide-by-two circuit and outside of the block to DMX1:16. Other divided down clock signals are formed and routed to DMX1:16 in similar fashion. A full rate clock divided-by-16 C16 is passed on to CLK Proc for additional phase adjustment.

## DMX1:16

The 1 to 16 Demultiplexer (DMX1:16) utilizes a tree type architecture that latches in the data stream from Data IB on both edges of a half-rate clock signal supplied by the divider (/16). The high speed data signal is subsequently demultiplexed down and delivered to LVDS DOBx16 in parallel fashion as 16-bit wide words running at a data rate up to  $f_{bit}/16$ .

## CLK Proc

By utilizing the CMOS control pins **phs1** and **phs2**, the phase of **cls** can be altered as shown in Table 1.

Table 1. Output Clock Phase Selection.

phs1	phs2	C16S phase
vee (default)	vee (default)	270°
vee	vcc	180°
vcc	vee	90°
vcc	vcc	0°

## LVDS DOBx16

The LVDS Data Output Buffer (LVDS DOBx16) accepts 16-bit wide words from DMX1:16 and converts them into LVDS output signals. Each proprietary low-power LVDS output buffer utilizes a special architecture that ensures operation at bit rates up to  $2Gb/s$  with a nominal output current of  $3.5mA$ . The buffer satisfies all the requirements of the IEEE Std. 1596.3-1996 and ANSI/TIA/EIA-644-1995 standards. The output MSB corresponds to **q00** when **bitordn=0** (default), or to **q15** when **bitordn=1**.

## LVDS COB

The LVDS Clock Output Buffer (LVDS COB) receives C16 from CLK Proc and converts it into the LVDS output signal **cls**. The proprietary low-power LVDS output buffer utilizes a special architecture that ensures



operation at frequencies up to 2.0GHz with a nominal output current of 3.5mA. The buffer satisfies all the requirements of the IEEE Std. 1596.3-1996 and ANSI/TIA/EIA-644-1995 standards.

## ABSOLUTE MAXIMUM RATINGS

Caution: Exceeding the absolute maximum ratings shown in Table 2 may cause damage to this product and/or lead to reduced reliability. Functional performance is specified over the recommended operating conditions for power supply and temperature only. AC and DC device characteristics at or beyond the absolute maximum ratings are not assumed or implied. All min and max voltage limits are referenced to ground (assumed *vee*).

Table 2. Absolute Maximum Ratings.

Parameter	Min	Max	Units
Supply Voltage ( <i>vee</i> )		+3.6	V
Power Consumption		0.8	W
RF Input Voltage Swing (SE)		1.2	V
Case Temperature		+90	°C
Storage Temperature	-40	+100	°C
Operational Humidity	10	98	%
Storage Humidity	10	98	%

## TERMINAL FUNCTIONS

<b>Supply And Termination Voltages</b>		
Name	Description	Pin Number
vcc	Positive power supply. (+3.3V)	5, 8, 11, 14, 25, 26, 29, 32, 35, 38, 41, 44, 47, 52, 55, 59, 62, 65, 68, 71, 76, 79, 82, 85, 88, 91, 94, 97, 100.
vee	Negative power supply. (GND or 0V)	1, 15, 17, 18, 23, 30, 36, 37, 50, 51, 58, 75.
nc	Not connected pins.	2, 19, 20, 21, 22, 24, 27, 28, 31, 42, 43, 45, 46, 48, 49, 53, 54, 74.

TERMINAL			DESCRIPTION
Name	No.	Type	
<b>High-Speed I/Os</b>			
dp	40	Input	CML differential data inputs with internal SE 50Ω termination to VCC.
dn	39		
cep	34	Input	CML differential clock inputs with internal SE 50Ω termination to VCC.
cen	33		
<b>Controls</b>			
phs1	57	LS In.,	Low-speed output clock phase selection (default: both low).
phs2	56	CMOS	
bitodr	16	LS In., CMOS	Output bit order selection (active: high, q15 is MSB; default: low, q00 is MSB).



TERMINAL			DESCRIPTION
Name	No.	Type	
<b>Low-Speed I/Os</b>			
q00n	10	Output	LVDS data outputs.
q00p	9		
q01n	7		
q01p	6		
q02n	4		
q02p	3		
q03n	99		
q03p	98		
q04n	96		
q04p	95		
q05n	93		
q05p	92		
q06n	90		
q06p	89		
q07n	87		
q07p	86		
q08n	84		
q08p	83		
q09n	81		
q09p	80		
q10n	78		
q10p	77		
q11n	73		
q11p	72		
q12n	70		
q12p	69		
q13n	67		
q13p	66		
q14n	64		
q14p	63		
q15n	61		
q15p	60		
clsp	12	Output	LVDS clock outputs. Can transmit four different clock phases as defined by <b>phs1</b> and <b>phs2</b> .
clsn	13		



## ELECTRICAL CHARACTERISTICS

PARAMETER	MIN	TYP	MAX	UNIT	COMMENTS
<b><i>General Parameters</i></b>					
vcc	+3.14	+3.3	+3.47	V	±5%
vee		0.0		V	External ground
Ivcc		221		mA	
Power consumption		730		mW	
Junction temperature	-25	50	125	°C	
<b><i>HS Input Data (d)</i></b>					
Data Rate	0	17	18	Gbps	
Swing p-p (Diff or SE)	0.04		0.8	V	Peak-to-peak
CM Voltage Level	vcc -0.8		vcc	V	
<b><i>HS Input Clock (ce)</i></b>					
Frequency	0.0	17	18	GHz	
Swing p-p (Diff or SE)	0.2		0.8	V	Peak-to-peak
CM Voltage Level	vcc -0.8		vcc	V	
Duty Cycle	40	50	60	%	
<b><i>LS Output Data (q00-q15)</i></b>					
Data Rate	0.0	1063	1125	Mbps	
Interface		LVDS			Meets the IEEE Std. 1596.3-1996
<b><i>LS Output Clock (cls)</i></b>					
Frequency	0.0	1063	1125	MHz	
Interface		LVDS			Meets the IEEE Std. 1596.3-1996
<b><i>CMOS Control Inputs/Outputs</i></b>					
Logic "1" level	vcc -0.4			V	
Logic "0" level			vee+0.4	V	
<b><i>Timing Parameters</i></b>					
"cls" to "q0-q15" delay variation		±2.5%			Over the full temperature range





## PACKAGE INFORMATION

The chip die is housed in a custom 100-pin CQFP package shown in Fig. 2. Additional package's mechanical information is available on the company's [website](http://www.adsantec.com).

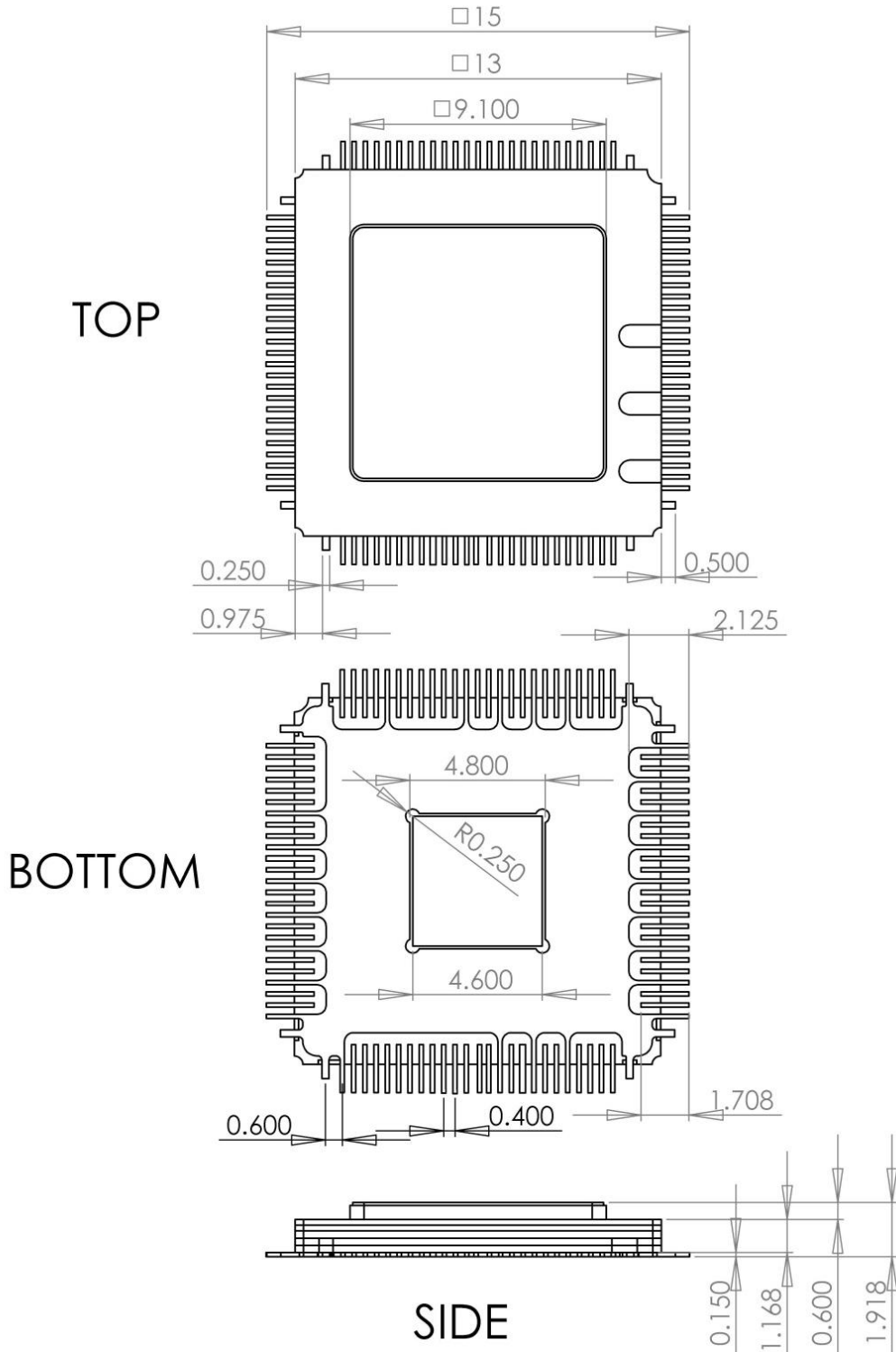

Fig. 2. Package Drawing.



The package's leads will be trimmed to a length of 1.0mm. After trimming, the package's leads will be further processed as follows:

1. The lead's gold plating will be removed per the following sections of J-STD-001D:
  - 3.9.1 Solderability
  - 3.2.2 Solder Purity Maintenance
  - 3.9.2 Solderability Maintenance
  - 3.9.3 Gold Removal
2. The leads will be tinned with Sn63Pb37 solder.

Even though the package provides a center heat slug located on the back side of the package to be used for heat dissipation, ADSANTEC does **NOT** recommend for this section to be soldered to the board. If the customer wishes to solder it, it should be connected to VCC plain that is power for the positive supply.

The part's identification label is ASNT2011-KMA. The first 8 characters of the name before the dash identify the bare die including general circuit family, fabrication technology, specific circuit type, and part version while the 3 characters after the dash represent the package's manufacturer, type, and pin out count.

This device complies with the Restriction of Hazardous Substances (RoHS) per EU 2002/95/EC for all six substances.

## REVISION HISTORY

Revision	Date	Changes
3.3.1	09-2012	Corrected input voltage range. Corrected format.
3.2	06-2012	Corrected package dimensions.
3.1	02-2012	Revised Description section Revised Package Information section
3.0	01-2012	Added Absolute Maximums Rating table. Revised Electrical Characteristics section. Revised Package Information section
2.0	02-2009	Revised Electrical Characteristics section. Revised Package Information section.
1.0	01-2009	First release.